

The **H100/MxF** by **HCI** is a 100% full port ball valve for use in complementing the **Terminator System** product line where integrated accessory features are not required. Like all **Terminator System** valves the **H100/MxF** boasts a state of the art forged brass body and hard chrome plated brass ball which insures reliable, leak-free performance.

The **H100/MxF** also features the "triple sealed stem". Utilizing a virgin PTFE gland packing and two Viton O-rings stem seals this valve ensures the most reliable and high cycle-life stem available anywhere. The **H100/MxF** is the perfect compliment to the incredibly high standard set forth by all the other **Terminator System** products.

Pressure/ Temperature Ratings:

1/4" - 3/4": 600 PSI WOG Non - Shock
 1": 500 PSI WOG Non - Shock
 All Sizes: 300 Deg. F. Maximum

Optional Accessories:

- Handle Extension - Memory Stop
- Red Aluminum T-Handle
- Stainless Steel Round Handle

Dimensional Information & Material Specifications:

Model #	Size	A	B	C	D	E	Cv*
H100-601	1/4"	1.85	0.93	1.41	0.39	2.95	11.84
H100-602	3/8"	1.85	0.93	1.41	0.39	2.95	11.84
H100-603	1/2"	2.44	1.22	1.53	0.59	3.74	20.25
H100-604	3/4"	2.71	1.36	1.88	0.79	3.74	41.83
H100-605	1"	3.30	1.65	2.36	1.00	4.72	78.38

Note: The Cv factor is the flow rate, in GPM through the valve at a 1 PSID.

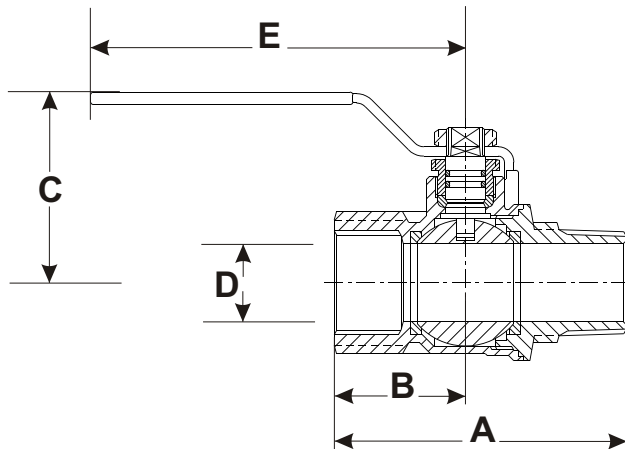

Valve Body:	Hot Forged Brass
Ball:	Chrome Plated/Hot Forged Brass
Stem:	Extruded Brass
Gland Nut:	Extruded Brass
Lever Handle:	Dacromet Coated Steel w/PVC Grip
Lever Nut:	Dacromet Coated Steel
Seats & Packing:	Virgin PTFE
O-Rings:	Viton

Typical Specifications:

Furnish and install where indicated on plans **H100/MxF** ball valves as provided by **Hydronic Components, Inc.** Valves shall be rated for 600 PSI WOG service (1/4"-3/4") AND 500 PSI WOG service (1"). Valves shall be provided complete with 100% port isolation valve chrome plated ball and repackable blowout-proof triple seal stem.

JOB: _____ ENGINEER: _____
 REP: _____ CONTRACTOR: _____