

HCI Terminator S

INTEGRATED BALL VALVE/STRAINER
WITH UNION & P/T READOUT PORT

MECHANICAL
SPECIFICATIONS



The **Terminator S** by **HCI** combines the features of an isolation valve, strainer, union, and pressure/temperature readout port into a single unit. The full port design of the **Terminator S** is favored by engineers because it minimizes terminal unit piping pressure drop, and the forged brass body insures reliable, leak-free performance. The **Terminator S** can reduce water and chemical loss by up to 99.9% when servicing the removable strainer basket.

The **Terminator S** greatly simplifies the contractor's job by eliminating up to several piping connections, thus saving time, money, and potential leak points. Finally, the **Terminator S** requires only one third the space of the components it replaces, making tough piping jobs a snap.

Pressure/ Temperature Ratings:

1/2" - 2": 400 PSI WOG Non - Shock
All Sizes: 250 Deg. F. Maximum

Optional Accessories:

- Drain Valve - Blow Down - Handle Extension - Air Vent
- PT/Port Accessory/Extension - Red Aluminum T-Handle
- Stainless Steel Round Handle - Fine Mesh Screens - Flex Hoses

Dimensional Information & Material Specifications:

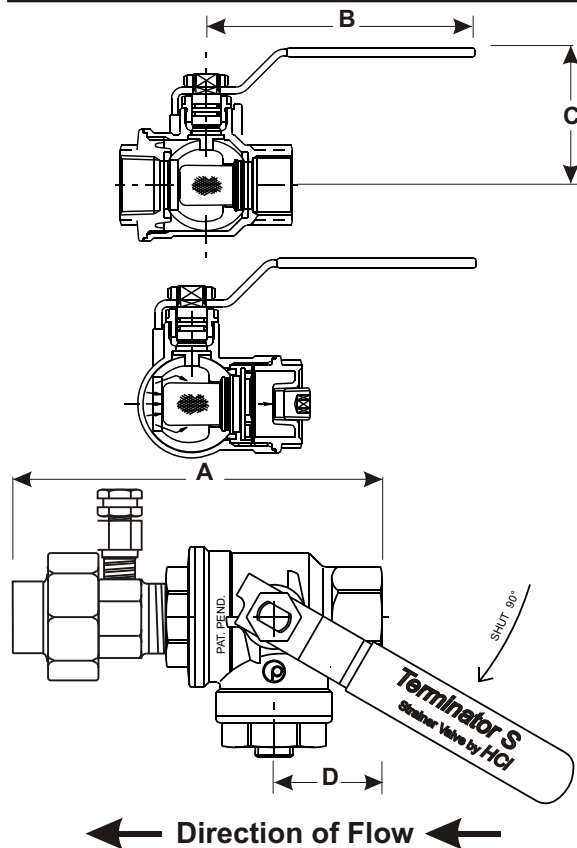

Model #	Size	A	B	C	D	Cv*
TS-AFF	1/2"	5.58	4.75	2.40	1.53	13.02
TS-BFF	3/4"	5.83	4.75	2.40	1.53	13.02
TS-CFF	1"	6.41	4.75	2.60	1.88	16.28
TS-DFF	1-1/4"	7.04	5.88	3.23	2.25	24.20
TS-EFF	1-1/2"	7.89	5.88	3.50	2.56	39.63
TS-FFF	2"	9.12	8.13	4.72	3.15	74.85

Note: The Cv factor is the flow rate, in GPM through the valve at a 1 PSID.

Valve Body, Union & Nut:	Hot Forged Brass
Ball:	Chrome Plated/Hot Forged Brass
Stem & Gland Nut:	Extruded Brass
Tailpiece:	Hot Forged Brass
Readout Port Body & Cap:	Extruded Brass
Readout Port Seal:	Nordel
Lever Handle:	Dacromet Coated Steel w/PVC Grip
Lever Nut:	Dacromet Coated Steel
Seats & Packing:	Virgin PTFE
O-Rings:	Viton
Filter Basket:	Stainless Steel / 20 Mesh Standard
Union Gasket:	EPDM
Union Insulator:	Glass Reinforced Nylon

Typical Specifications:

Furnish and install where indicated on plans **Terminator S** integrated terminal unit accessory valves as provided by **Hydronic Components, Inc.** Valves shall be rated for 400 PSI WOG service, (1/2"-2"). Valves shall be provided complete with 100% port isolation valve chrome plated ball and repackable blowout-proof triple seal stem. Integral strainer shall be 20 mesh stainless steel, capable of being serviced without disturbing piping connections and without draining pipe or coil. Dielectric union shall be provided complete with pressure/temperature readout port. Available with Female NPT, Male NPT or Copper Sweat end connections. Single nominal size reduction (3/4"-2") and double nominal size reduction (1"-2").

JOB: _____ ENGINEER: _____
REP: _____ CONTRACTOR: _____



innovative hydronic components and accessories for the HVAC industry.
7243 Miller Drive - Suite 200 - Warren, MI 48092 Phone: 1-800-313-HVAC Fax: 1-866-340-0991

HCI-15/1-08

This specification is provided for reference only. HCI reserves the right to change any portion of this specification without notice and without incurring obligation to make such changes to HCI products previously and subsequently sold.